

# PV-Wind Hybrid System Optimization Using Improved Fuzzy Logic Control

Boubacar Sidiki Kanté<sup>1,\*</sup>, Mamadou Dansoko<sup>2</sup>, Fadaba Danioko<sup>2</sup>,  
Bourema S. Traore<sup>3</sup>, Moussa Sangare<sup>2</sup>, Abdramane Ba<sup>3</sup>, Mamadou Lamine Doumbia<sup>4</sup>

<sup>1</sup>Hybrid Renewable Energy Laboratory (HREL), Physics Department, USTTB-FST, B.P. E 3206 Bamako, Mali

<sup>2</sup>Computing of Modellings and Simulations center (CMSC), Physics Department, USTTB-FST, B.P. E 3206 Bamako, Mali

<sup>3</sup>Laboratory of Optics, Spectroscopy and the Atmospheric Sciences (LOSSA), Physics Department,  
USTTB- FST, B.P. E 3206, Bamako, Mali.

<sup>4</sup>Department of Electrical and Computer Engineering, University du Quebec à Trois rivières C.P 500

\*Corresponding author: [bouba\\_kante@yahoo.fr](mailto:bouba_kante@yahoo.fr)

*Received May 08, 2024; Revised June 11, 2024; Accepted June 18, 2024*

**Abstract** Renewable energy production sources became very attractive in recent years due to environmental problems and their enormous potential. Many studies have been done on these systems alone and combined operation. Among these combined systems, a particular attention is made on the combined PV-Wind system in the literature due to the great sources complementarity and the resource availability in tropical countries as in Mali. Nowadays, PV-Wind system hybridization is an alternative solution to traditional and nuclear energy sources which are the most used to cover the worldwide energy consumption. This system represents an economic and environmental option. Their complementarity improves the service quality compared to PV or wind power single system. A maximum power point tracking controller is required for the electrical power generation profitability. This controller must take into account the sources of intermittent nature and the random variations of climatic parameters. The fuzzy logic controller operates with imprecise input values and can deal with nonlinear equations. This paper presents energy sources modeling and simulation results on fuzzy logic improving (FLI) for hybrid PV-Wind system power optimization. Firstly, a model of each generator is developed and the fuzzy logic rules are defined. Secondly, these models are designed under Matlab/Simulink in order to study their behavior in simulation. Finally, a comparative study is realized between the proposed control and the fuzzy logic controller (FLC) using a fixed gain. The obtained results show the proposed method effectiveness compared to FLC in terms of power optimization and oscillations damping after perturbation.

**Keywords:** *hybrid system, renewable energy, simulation, fuzzy logic, optimization*

**Cite This Article:** Boubacar Sidiki Kanté, Mamadou Dansoko, Fadaba Danioko, Bourema S. Traore, Moussa Sangare, Abdramane Ba, and Mamadou Lamine Doumbia, "PV-Wind Hybrid System Optimization Using Improved Fuzzy Logic Control." *American Journal of Energy Research*, vol. 12, no. 2 (2024): 33-39. doi: 10.12691/ajer-12-2-1.

## 1. Introduction

The electrification rate in Mali is estimated at 42% of national coverage to 2017 [1]. As a result, it will be interesting to develop renewable energy systems, such as photovoltaic or wind which are very interesting for countries like Mali. Photovoltaic or wind power system produces energy according to the daytime, season and geographical location.

The combination of two complementary renewable generation sources (photovoltaic and wind) with energy storage can achieve higher yields compared to a single energy source [2]. Both of these energy sources are subjected to fluctuations in energy production due to their intermittent nature [3].

Power optimization algorithms can be classic

(perturbation and observation P&O, conductance by increment IC, optimization by particle test PSO...) or intelligent (artificial neural network ANN, fuzzy logic FL ...). The first group of algorithms is easy and simple to implement, but, in permanent regime they present oscillations around the maximum power point and a slow dynamic compared to random disturbances [4,5,6]. In the second group, the neural network requires a slow learning time and regular revision [7]. This behavior is unsuitable to fast and aleatory dynamic systems. The Fuzzy logic operates with imprecise input values and can deal with nonlinear equations [7]. This fact is interesting for hybrid system optimization comprising nonlinear sources subjected to random constraints. For these reasons, several studies have been carried out to improve the fuzzy logic control efficiency. The authors of [8] have designed an artificial neural network with fuzzy logic to optimize the hybrid system production. The obtained results of this

technique are compared to those of a fuzzy logic controller and an artificial neural network. These results are encouraging, only, the proposed model is very complex and the neural network requires a slow learning time and regular revision. In [9,10], the authors have used the PI controller with fuzzy logic to control the voltage of isolated micro-grids. The results show that the PI-Fuzzy controller regulates more than the voltage compared to PI and classic Fuzzy Logic. The authors of [11] have combined the firefly theory with fuzzy logic for PV-wind system optimization. The firefly theory used requires a learning and adaptation long time that can reduce the controller performance for systems with fast dynamics such as wind turbines. In paper [12], the authors have added a fixed gain to fuzzy logic to optimize a hybrid system and the authors of [13] have shown that by associating the fuzzy logic to a gain which varies according to the control error, we can improve the system performance. The obtained results in [13] showed that this technique improves the fuzzy logic behavior, but it is only applied to a PV system. The actual challenge being to increase the renewable energy production, it will be interesting to study and analyze the combination of developed techniques in [12] and [13] on hybrid PV-Wind system optimizing.

In this article, we propose an improved fuzzy logic (FLI) control to optimize a PV-wind hybrid system power. The proposed FLI combines the improved techniques developed in papers [12] and [13] in order to increase more the fuzzy logic effectiveness. The results obtained via the technique will be compared to those obtained by the fuzzy logic technique in [12].

The rest of this document is organized as follows: a hybrid system modeling is presented in section 2, in section 3, a fuzzy logic theory is described and in section 4, a comparative study is realized in order to highlight the proposed technique performance compared to FLC developed in [12]. Finally, a conclusion is given in section 5.

## 2. Methology

### 2.1. Photovoltaic Modeling

The PV cell can be modeled from an electrical circuit, where the cell is represented by a current source, one or two diodes and two resistors one of which is connected in series and another in parallel. The most commonly used model for the PV cell is the equivalent circuit to one diode which is illustrated by Figure 1.

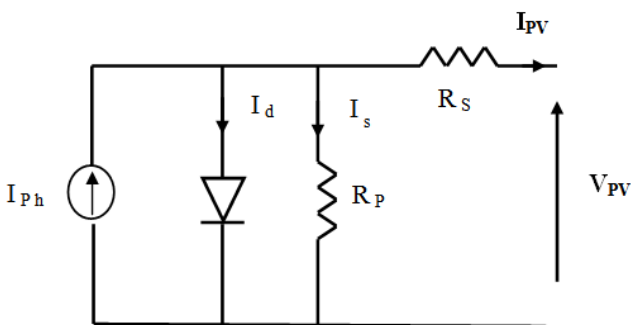

Figure 1. PV equivalent circuit to one diode [14,15]

The produced current at the PV cell output and the terminal voltage is given by equations (1) and (2). These equations are given by [16,17]:

$$I_{PV} = I_{PH} - I_S \left( e^{\left( \frac{V + R_S I_{PV}}{nV_T} \right)} - 1 \right) - \frac{V + R_S I_{PV}}{R_P} \quad (1)$$

$$V_{PV} = n.V_T . e \left( 1 + \frac{I_{PH} - I_{PV}}{I_S} \right) - I_{PV} R_S \quad (2)$$

Where: IPV is PV current, IPH is Photocurrent, Is is saturation current, Rs is Serie resistance, Rp is Shunt resistance, V is Output voltage and VT is Thermal voltage.

### 2.2. Wind Turbine Modeling

The wind generator is composed of a horizontal axis turbine coupled directly to a permanent magnet synchronous generator (PMSG). Although the wind turbines drive generally the asynchronous generators, the PMSG is advantageous in terms of energy conversion efficiency and the generator excitation simplicity. For these reasons, we use the PMSG in this study. The global conversion chain is represented in Figure 2.

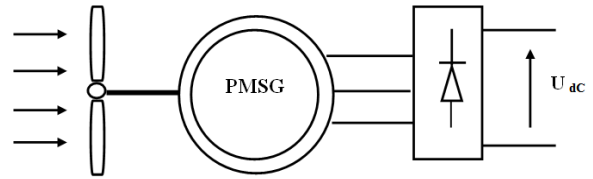

Figure 2. Wind power conversion chain [7]

Wind turbine modeling must take all the conversion chain components into account, especially the wind turbine aerodynamic model, the mechanical drive model, the generator and power converter models [6].

The wind turbine transforms the wind kinetic energy into mechanical energy. It is modeled by its extracted power for equation (3).

The PMSG mathematical model is given on the following assumptions basis:

- The saturation absence in the magnetic circuit;
- Hysteresis phenomenon is neglected with Foucault currents and skin effect;
- The encoding effect is negligible;
- The windings resistor does not change with temperature.

The PMSG is governed by the following dynamic equations (4). These equations are given by [7,18,19,20,21]:

$$P = \frac{1}{2} C_P \rho V^3 \quad (3)$$

$$\begin{cases} J \frac{d\omega}{dt} = C_{em} - C_r - F\omega \\ C_{em} = \frac{3}{2} P (L_d - L_q) i_d i_q + \phi_F i_q \\ \frac{di_{ds}}{dt} = \frac{V_{ds}}{L_d} - \frac{R_s i_{ds}}{L_d} + \omega_r L_q \frac{i_{qs}}{L_d} \\ \frac{di_{qs}}{dt} = \frac{V_{qs}}{L_q} - \frac{R_s i_{qs}}{L_q} - \omega_r L_q \frac{i_{ds}}{L_q} + \frac{\omega_r}{L_q} \phi_F \end{cases} \quad (4)$$

Where: P is power, Cp is power coefficient, ρ is Air density, J is Inertia, Cem is Electromagnetic torque, Cr is Resistant torque, Rs is stator resistance, ω is Rotational speed, t is time, φ is Flux generated by permanent magnet and Vds, Vqs, ids, iqs, Lds, Lqs are voltage, current and inductances of stator axe d and q.

### 2.3. Boost Converter Modeling

For an effective adaptation of the PV and the other systems, a DC-DC converter has been applied. The control of this converter is strictly maintained to ensure a constant DC voltage level [22]. The boost converter associated with electrical circuit is depicted in Figure 3

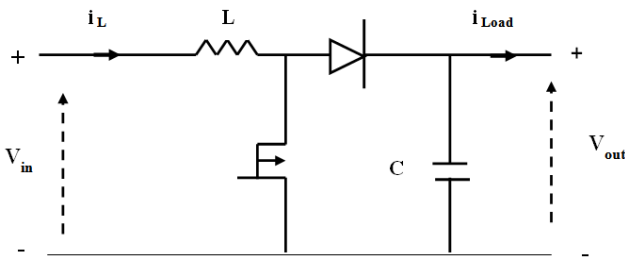

Figure 3. The boost converter's electrical mode [17]

The DC bus voltage (output voltage) is expressed by a function of the PV voltage, such as:

$$V_{out} = \frac{V_{in}}{1-d}$$

With d is the duty cycle ( $d_{pv}$  or  $d_{wind}$ ).

### 2.4. Fuzzy Logic Theory

Fuzzy logic theory allows only to make modeling and rigorous process of imprecise uncertain and subjective information, but also the nonlinear functions approximation.

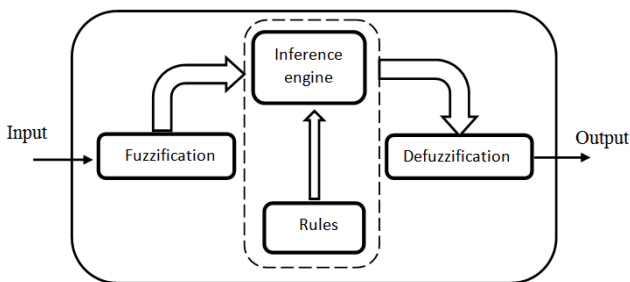

Figure 4. Fuzzy MPPT controller structure [23]

This technique is designed as follows.

The fuzzification interface allows the real world to fuzzy world passage. This is the first step of problem treatment by fuzzy logic. It consists of modeling each system inputs by curves giving the belonging degrees to different identified states. Generally, we use triangular and trapezoidal belonging functions due to their capacity to facilitate the fuzzification step and the computation time.

The rules interface allows the data processing. The fuzzy control system comprises a number of rules linking fuzzy sets (based on the logic rule) having the form “if-then”.

The defuzzification interface allows the fuzzy world to real world passage. The output variable is computed from the belonging degrees. The most used defuzzification strategies are: the Maximum Method, the Average Maximum Method, the Gravity Center Method and the Weighted Heights Method.

Figure 5 present the structure of the proposed fuzzy MPPT controller. It has two inputs and one output. The two input variables of fuzzy controller are the error (E) and the error variation (dE) which is taken at each sampling step. The output variable (d) represents the duty cycle increment. The coefficients K1 and K2 are in table 1.

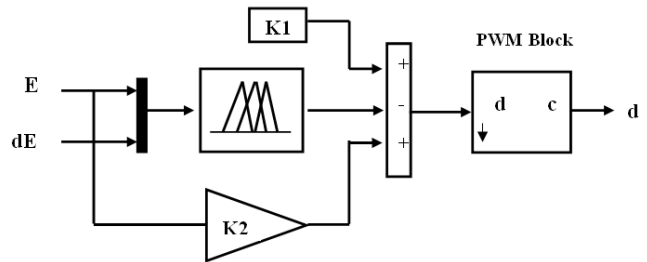

Figure 5. Diagram of the Fuzzy technique

Table 1. Parameters of controllers

Gain	PV	Wind
K1	0.4	0.1
K2	0.4	0.8

The two inputs E and ΔE for the PV generator are defined by equations (5) and (6). These equations are given the [24].

The two inputs E and ΔE for the wind generator are defined by equations (7) and (8). These equations are given by [25]:

$$E(K) = \frac{P(k) - P(k-1)}{V(k) - V(k-1)} \tag{5}$$

$$dE(K) = E(K) - E(K-1) \tag{6}$$

$$E(K) = \frac{P(K) - P(K-1)}{\omega(K) - \omega(K-1)} \tag{7}$$

$$dE(K) = E(K) - E(K-1) \tag{8}$$

Figure 6 and Figure 7 show respectively the Belonging functions for PV and for Wind turbine. Figure 8 represents the hybrid system.

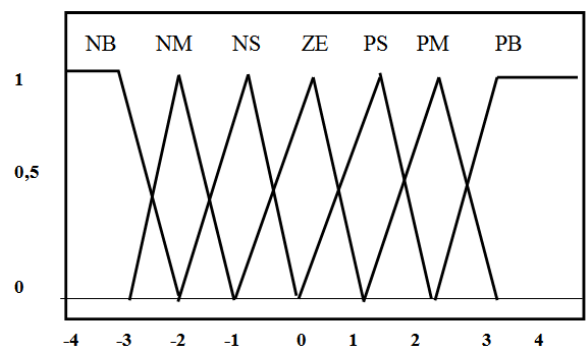

a: input E

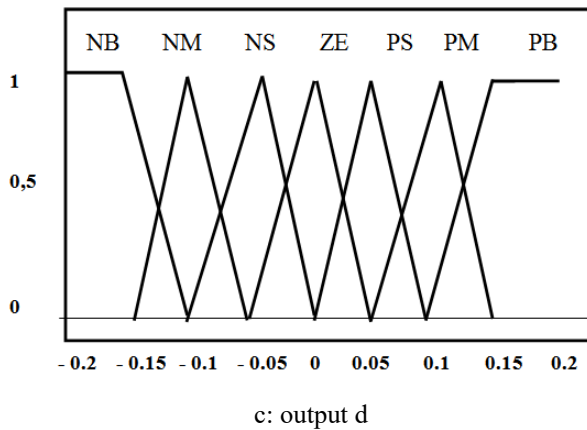
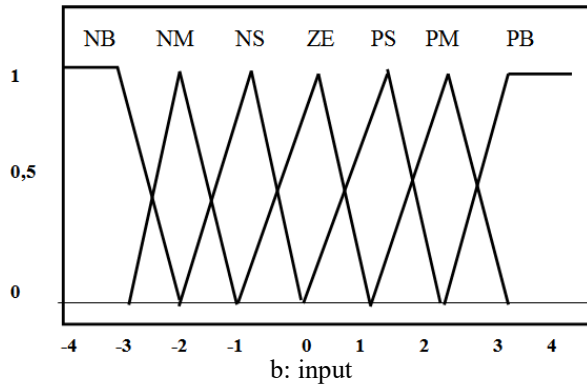

Figure 6. Belonging functions for PV

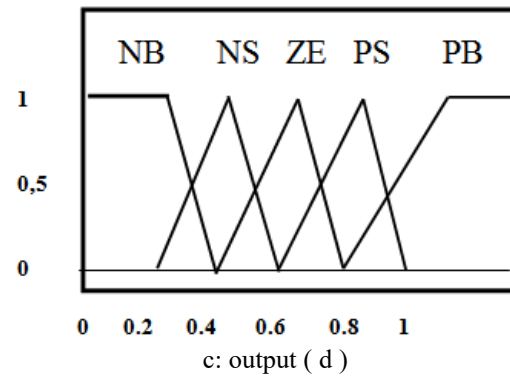
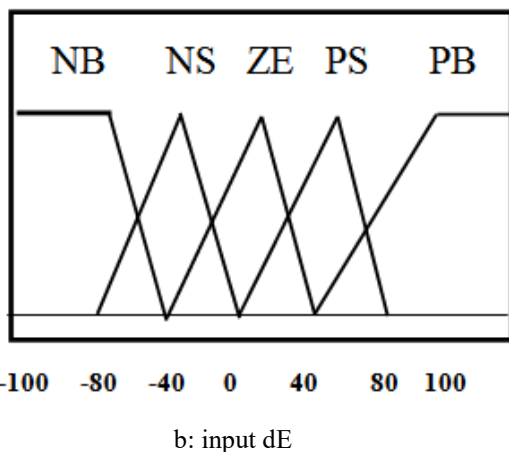
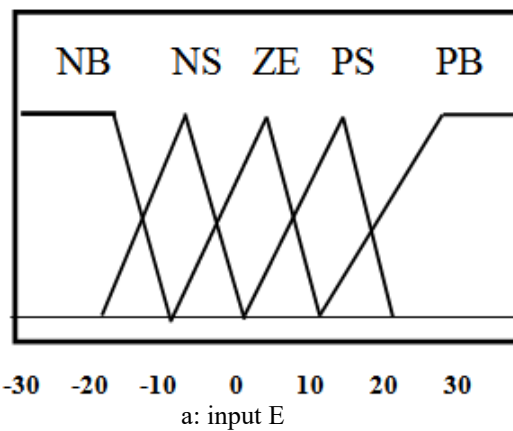

Figure 7. Belonging functions for Wind

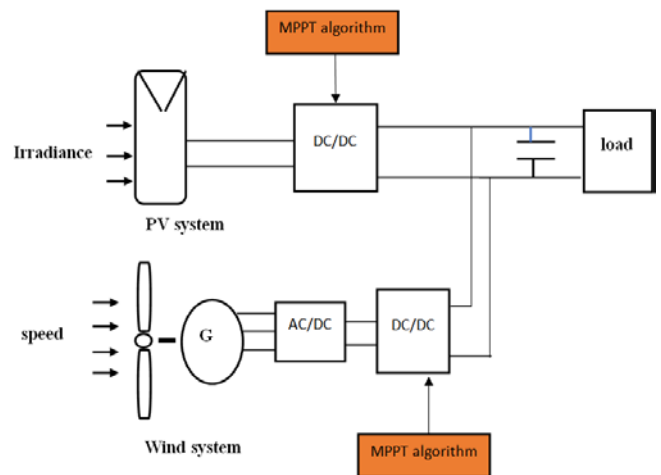

Figure 8. Diagram of the hybrid system

### 3. Results and Discussion

The PV and wind generators models are simulated under MATLAB/Simulink environment. Simulations are performed with two decentralized controllers, one for each hybrid system source.

The wind speed which is the input element of wind turbine varies from 5 m/s to 6 m/s after 4s.

After 4s, the PV system input element which is the irradiance varies from 750 to 700 W/m<sup>2</sup>.

The obtained simulation results are represented in Figure 9 and Figure 10.

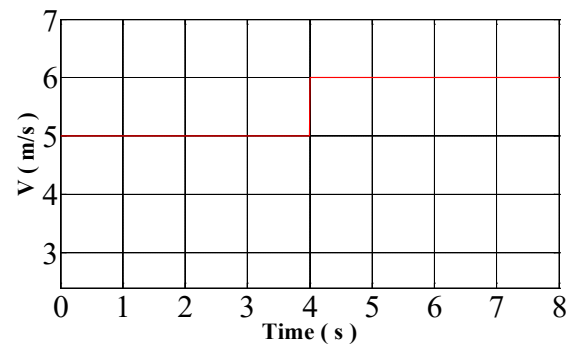

a: Speed of the Wind

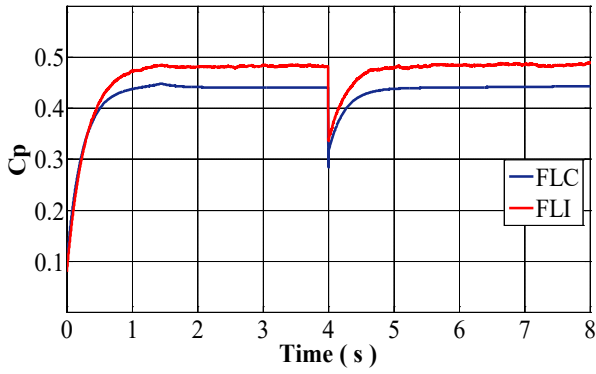

b: Coefficient of power

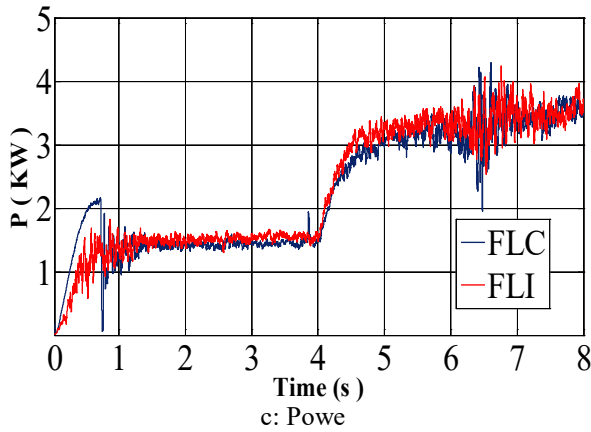

c: Power

Figure 9. Wind turbine curves

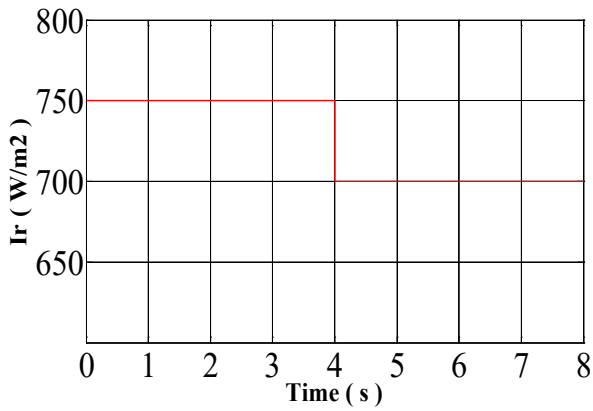

a: Irradiation

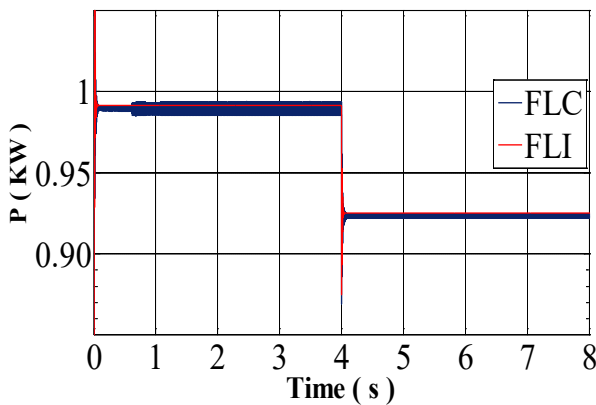

b: Power

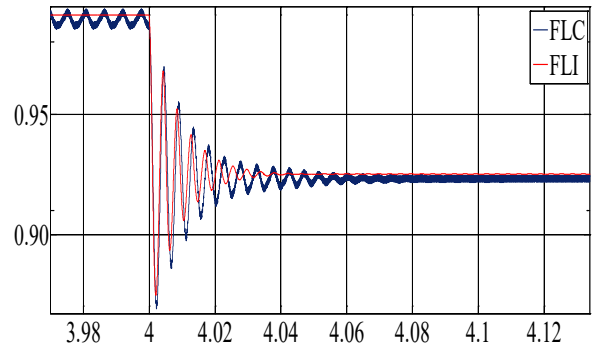

c: Zoom on power

Figure 10. PV curves

The electrical power and the power coefficient curves for wind turbine are shown in Figure 9. It is noted that the wind speed variation generates a wind turbine power variation which increases from 1.5 to 3.85 KW with the FLI controller and from 1.4 to 3.7 KW with the FLC. These obtained results show that the proposed method (FLI) compared to FLC allow to optimize the wind turbine power with an efficiency around 4.7 %. It is noted that this result is higher than the obtained results by O. Zebraoui & al in 2020 and A. Borni & al in 2021 which have obtained respectively, 0.11% with hybrid FL-HCS controller compared to the LF and 7.14% with hybrid FL-PSO compared to the FL-GA.

The PV generator power and the power zoom are shown in Figure 10. The transient regime after the irradiation perturbation presents some oscillations which are better damping by the FLI compared to FLC. From obtained results, the proposed FLI presents an improvement of 0.2% compared to FLC. This result is the same of that obtained in H. Othmani & al works in 2015, except that authors compared the FL controller to the classical method P&O. It is higher than the obtained result by O. Zebraoui & al in 2020 which have compared the controller FL-HCS to the FL with improvement of 0.12%.

The table 2 summarizes and compares the performance of controllers. Globally, the proposed FLI method allows a net optimization whatever the wind turbine power and a lower optimization for low PV power which can be significant if the PV power achieve the megawatt.

Table 2. Transient response of the Wind controllers

Performance Indicator	Wind		PV	
	FLC	FLI	FLC	FLI
Rise Time 5% (s)	0,5	0,5		
Settling Time (s)	0,9	0,75	2,2. 10 <sup>-3</sup>	2,0. 10 <sup>-3</sup>
Overshoot (%)	5,7	3,48	6,48	5,32

Besides the optimization criterion, we have analyzed the proposed method of performance compared to other technique in literature following the settling time. This comparative result is illustrated in table 3 and table 4.

We note that the proposed controller of the wind turbine improves the settling time by 25% and 58% compared to certain CMPN\_FL and FL correctors respectively used in the works of Soliman & al 2019 and

Mahmoud & al 2022. For the PV system, the proposed controller improves more than 73% the settling time compared to the obtained results in the Fuzzy Logic power optimization work carried and Aiswarya & al 2020.

**Table 3. Wind**

Reference methods	MPPT Technique	Settling Time (s)
Mahmoud al 2022[26]	FLC	2,19
Soliman al 2019[27]	CMPN-FLC	1,2
Proposed method	FLI	0,9

**Table 4. PV**

Reference methods	MPPT Technique	Settling Time (s)
Aiswarya al 2020[28]	FLC	0,0075
Proposed method	FLI	0.002

## 4. Conclusion

In this study, we have proposed a fuzzy logic improvement for PV-Wind hybrid system power optimization. First of all, a mathematical model of each generator is proposed, then, a set of rules are defined for the inputs and outputs of an improved fuzzy logic. Finally, the proposed FLI and the FLC are applied to the PV-Wind hybrid system designed and simulated in Matlab/Simulink environment. The obtained comparative results have proved that the proposed FLI is better than FLC in terms of optimization power and damping oscillation after perturbation. The power improvement of proposed controllers is of 4.7% for wind turbine and 0.2% for PV system. Our proposed controller improves also the sources dynamic response with a settling time of more than 25% compared to some optimizations in the literature. From these results, we can conclude that the proposed FLI improves the power optimization regardless the wind turbine power and can be interesting only on the PV system at great power.

## Nomenclature

FLI	Fuzzy Logic Improving
FLC	Fuzzy Logic Controller
PV	Photovoltaic
P&O	Perturb and Observe
PSO	Optimization by Particle Test
IC	Incremental conductance
ANN	Artificial Neural Networks
HCS	Hill Climbing Search
GA	Genetic Algorithm
FL-PSO	Fuzzy Logic - Particle Swarm Optimization
FL-HCS	Fuzzy Logic -Hill Climbing Search
CMPN-FLC	Continuous Mixed P-Norm-Fuzzy Logic Controller
DC	Direct Current

## References

- [1] Direction Nationale de l'Energie. Prospectus d'investissement de l'énergie durable pour tous SeforAll du Mali. Bamako, Mai 2019. ([https://www.se4all-Africa.org/fileadmin/uploads/se4all/Documents/Country\\_AAs/PI\\_SEforALL\\_MALI.pdf](https://www.se4all-Africa.org/fileadmin/uploads/se4all/Documents/Country_AAs/PI_SEforALL_MALI.pdf)).
- [2] Kaiqi S, Li K J, Jiuping P, Yong L, Yilu L. An optimal combined operation scheme for pumped storage and hybrid wind-photovoltaic complementary power generation system. 2019; 242: 1155-1163.
- [3] Xu L, Zhiwei W, Yanfeng L, Xing L. Energy allocation strategy based on fuzzy control considering optimal decision boundaries of standalone hybrid energy systems. Journal of Cleaner Production. 2021; 279: 123810.
- [4] Venkata P M, Meyyappan S, Alla R R. Maximum Power Point Tracking with Regression Machine Learning Algorithms for Solar PV systems. International Journal of Renewable Energy Research 2022; 12 (3): 1327-1338.
- [5] Gouabi H, Hassab A, Habbab M, Rezkallah M, Chandra A. Experimental implantation of a novel scheduling algorithm for adaptive and modified P&O MPPT controller using Fuzzy logic for wecs. Adaptive Control and Signal Processing 2021: 1732-1753.
- [6] A. Elmetwaly, R. A. Younis, A. A. Abdelsalam, A. I. Omar, M. M. Mahmoud, F. Alsaif, A. El-Shahat & M. A. Saad. Modeling, simulation, and Experimental Validation of a Novel MPPT for Hybrid Renewable Sources Integrated with UPQC An Application of Jellyfish Search Optimizer. Sustainability. 2023; 15, 5209.
- [7] Mida, D. Contribution à la modélisation d'un système de production d'énergie électrique hybride éolien – photovoltaïque. Université Mohamed Khider-Biskra. Thèse, 2019. <https://thesis.univ-biskra.dz/view/divisions/dep=5Felect/2019.html>.
- [8] Elaissoui H, Zeraouali M, Abbdelghani E O, Tidhaf B. MPPT Algorithm based on Fuzzy Logic and Artificial Neural Network (ANN) for Hybrid Solar/Wind Power Generation System. International Conference ON Intelligent Computing in Data Sciences, Morocco 2020.
- [9] Keshta H E, Ali A A, Malik O P, Saied E M, Bendary F M. Voltage control of islanded hybrid micro-grids using al technique. Electric Power and Energy Conference. 2020.
- [10] Mansour S, Badr A O, Attia M A, Sameh M A, Kotb H, Algaml E, Shouran M. Fuzzy Logic Controller Equilibrium Base to Enhance AGC System Performance with Renewable Energy Disturbances. Energies. 2022, 15: 6709.
- [11] Priyadarshi N, Ramachandaramurthy V K, Sanjeevikumar P, Farooque A. An Ant colony optimized MPPT for standalone hybrid PV-Wind power system with single cuk converter. Energies. 2019; 12: 167.
- [12] Khan M J, Lini M. Fuzzy logic controller-based MPPT for hybrid photo-voltaic/wind/fuel cell power system. Neural Computing and Application. 2018.
- [13] Nassar-Eddine I, Abdellatif O, Et-Torabi K, Hamza M, Assiya E, Redouane R, Youssef E, El Fajri A, Smail S, Mustapha A. A new fuzzy logic architecture to control the DC bus voltage in grid connected photovoltaic system. ICCSRE, Morocco. 2019.
- [14] Wael S H, Marwa M A, Osama M A R, Mohamed G, Mohamed I M. Performance improvement of grid hybrid renewable energy system using dynamic voltage restorer. Alexandria Engineering Journal. 2020; 59: 1567-1581.
- [15] Touré A F, Danioko F, Diourte B. Application of Artificial Neural Networks for Maximal Power Point Tracking. International Journal of Sustainable and Green Energy. 2021; 10(2): 40-46.
- [16] Samir Arfa, Mohsen Ben Ammar, Hsan Hadj Abdallah. Multi-Source Renewable Energy Exchange Management System for Off-Grid Home Load. International Journal of Renewable Energy Research. 2022; 12 (3): 1463-1474.
- [17] Zebraoui O, Bouzi M. Improved MPPT controls for a standalone PV/wind/battery hybrid energy system. International Journal of Power Electronics and Drive System. 2020; 11(2): 988-1001.
- [18] Borni A, Bechouat M, Bessous N, Laid A B Z, Layachi Z. Comparative Study of P&O and Fuzzy MPPT Controllers and Their Optimization Using PSO and GA to Improve Wind Energy System. International Journal for Engineering Modelling. 2021; 34(2).
- [19] Anthony M, Prasad V, Kannadasan R, Mekhilef S, Alsharif M H, Kim M K, Jahid A, Aly A A. Autonomous Fuzzy Controller Design for the Utilization of Hybrid PV-Wind Energy Resources in Demand Side Management Environment. Electronics. 2021; 10: 1618.
- [20] Mahmoud M M, Salama H. S, Aly M. M. & Abdel-Moamen M.A. Design and implementation of FLC system for fault ride-through capability enhancement in PMSG-wind systems. Wind Engineering. 2020: 45(7).

- [21] M M Mahmoud, M. Aly, H. S. Salama & M.A Abdel-Moamen Dynamic evaluation of optimization technique-based proportional-integral controller for wind-driven permanent magnet synchronous generator. *Wind engineering* 2020.
- [22] Samir A, Mohsen B A, Mohamed A Z, Hsan H A. Multi-Source Renewable Energy Exchange Management System for Off-Grid Home Load. *International Journal of Renewable Energy Research*. 2022; 12(3).
- [23] Shehbab A A, Kassas M, Khalid M, Abido M A. An Energy System for Residential Autonomous DC Microgrid Using Optimized Fuzzy Logic Controller Considering Economic Dispatch. *Energies*. 2019; 12,1457.
- [24] Avinash K P, Varsha S, Sachin J. Study and comparative analysis of perturb and observe (P&O) and fuzzy logic based PV-MPPT algorithms. *Applications of AI and IOT in Renewable Energy*. 2022: 193-209.
- [25] Zebraoui O, Bouzi M. Comparative study of different MPPT methods for wind energy conversion system. *International Conference on Renewable Energies and Energy Efficiency*. 2018; 161.
- [26] Mahmoud M. M., Mohamed M. A. , Hossam S. S., Abdel-Moamen M. A. R. A combination of an OTC based MPPT and fuzzy logic current control for a wind-driven PMSG under variability of wind speed. *Energy Systems*. 2022: 13(4) 1075-1098.
- [27] Soliman A. M. , Hany M. H. , Haitham Z. A., El-Kholy E. E. , Mahmoud S. A. An Adaptive Fuzzy Logic Control Strategy for Performance Enhancement of a Grid-Connected PMSG-Based Wind Turbine. *Transactions on Industrial Informatics*. 2019: 6(15) 3163-3173.
- [28] Aiswarya C, Bobin K. M. Comparative Analysis of P&O and Fuzzy Logic Controller based MPPT in a Solar cell. *Proceedings of the Third International Conference on Smart Systems and Inventive Technology*. 2020: 622-626.



© The Author(s) 2024. This article is an open access article distributed under the terms and conditions of the Creative Commons Attribution (CC BY) license (<http://creativecommons.org/licenses/by/4.0/>).